

Warnings!
请注意!



The cabinet, chassis or guide rails may cause scratches, please be careful.
机柜或者服务器机箱、导轨可能造成划伤！
When installing new servers into the rack in use, please be aware of electric shock.
在正在使用的机柜中安装新服务器时，请谨防触电！

- When installing 4U or bigger models, 4 people are needed at least.
安装4U或更大的机型时，至少需要4个人。
- During installation process, please don't block the vents on the server, especially the vents on the front and rear end of the server.
安装时请注意不要阻塞服务器上的通风孔，尤其是服务器前、后部的通风孔。
- Please remove the protective film on the server surface before using.
请在使用之前将服务器外壳上的保护膜撕去。
- Please leave 15cm minimum of clearance on the front and rear sides of the server for proper ventilation.
服务器的前、后部需至少留出15厘米空间，以便于系统散热。
- Please install air baffles for the position without device installed, to make sure that the server can get enough air flow, and to avoid air turbulence in the server room.
没有安装设备的机柜位置，请始终安装挡风盲板，以确保服务器获得足够的气流，并避免机房气流紊乱。
- Servers are high-power electrical appliances, and they should be installed into the dedicated cabinets with vents or professional water-cooled cabinets, to prevent system failures caused by overheating.
服务器是高功耗电器，只能安装在带有通风孔的专用机柜，或者专业水冷机柜中，以免过热造成系统失效。
- If it needs to install more than one devices, please load from the bottom up, and load the heaviest items first.
如果要安装多台设备，请先从机柜靠下的空位开始，并将较重的设备安装在机柜下部。
- Please note the cabinet's bearing capacity, power supply capacity and heat dissipation capacity, be sure not to install devices beyond the cabinet's bearing capacity.
请注意机柜的承重、供电及散热能力，切勿安装超出机柜承载能力的设备。
- For the convenience of using the front and rear ports of the server and cabling, leave 70mm minimum of clearance between the front end of the server and the inner side of the cabinet's front door, and leave 150mm minimum of clearance between the rear end of the server and the inner side of the cabinet's rear door.
为了便于使用服务器前、后部的接口，并便于布线，服务器前部与机柜前门内侧之间至少留出70毫米、后部与机柜后门内侧之间至少留出150毫米距离。

15kg



If the device is more than 15kg, 2 people are needed at least.
安装超过15千克的设备时，至少需要2个人！

30kg



If the device is more than 30kg, 3 people are needed at least.
安装超过30千克的设备时，至少需要3个人！

50kg



If the device is more than 50kg, 4 people are needed at least.
安装超过50千克的设备时，至少需要4个人！



编码

Rack-mounted Server Installation Guide

机架式服务器 上架安装指南

V1.0

Please keep this document for checking in the future.
请保留本文档，以便于日后查阅。

Identifying the Rail Kit Contents

服务器上架所需部件

Rail Kit is assembled by inner rail, middle rail and outer rail.
导轨套件是由内轨，中轨和外轨组装。



Installing Rails

安装导轨

- 1 Remove the inner rails from the rail. Press members and remove the inner rail in the direction of the arrow.
从导轨中取出内轨。按下部件并依箭头方向取出内轨。

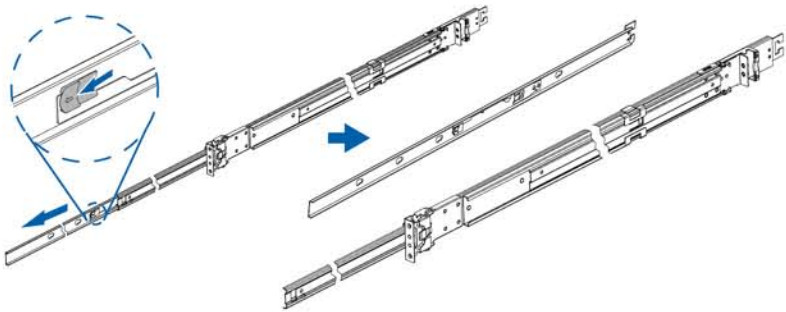

- 2 Middle rail within the rail return. Press this part in the direction of the arrow back in the middle rail.
中轨返回滑轨内部。按下部件依箭头的方向收回中轨。

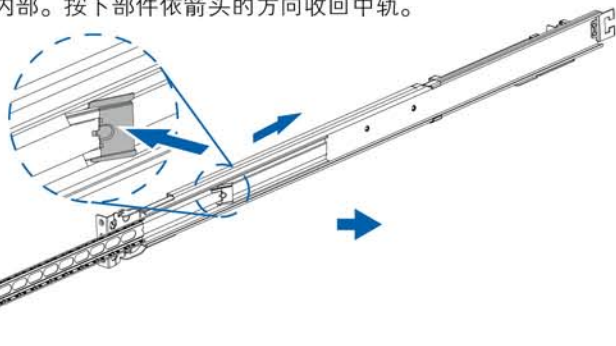

- 3 Check the location of the rail and the front and rear bracket on cabinet.

- a. Install the rear bracket on the corner posts.
在机柜上确认好导轨前后支架的安装位置。
- b. Install the front bracket on the corner posts.
a. 安装后支架在机柜上。
b. 安装前支架在机柜上。

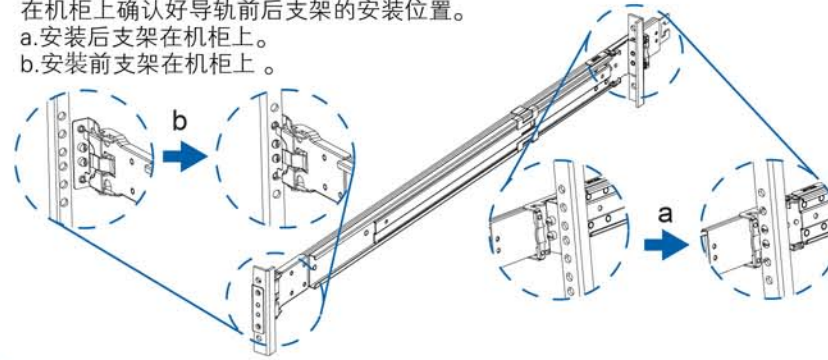

- 4 Install the inner rail to the chassis.
内轨安装在服务器上。

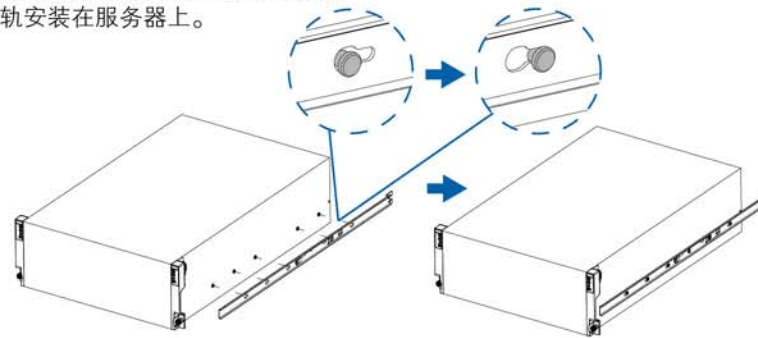

- 5 Chassis into the cabinet.

- a. Make sure the ball-bearing retainer is at the front of intermediate member, then aim and push the inner member (chassis installed) into the intermediate/outer member.
 - b. Pull/push two-way release button to release lock-out feature. Complete retracting the chassis into the rack. Locate and tighten the screws under each handle on the system.
- 服务器装入机柜。
a. 要确保球巢是否在中轨前端，然后将装好内轨的服务器对准中外轨装入。
b. 推/拉双向释放件释放外部定位，得以将服务器完全收回，找到并拧紧系统上的每个手柄下的螺丝钉

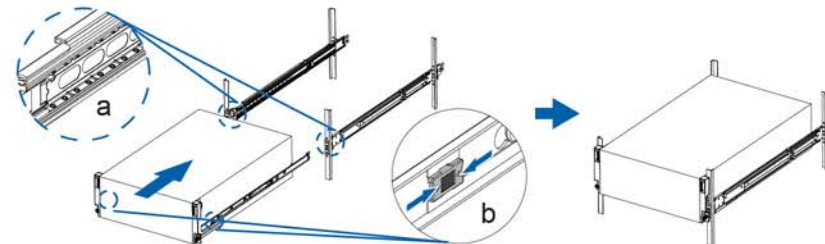

Removing Rails

卸除导轨

- 1 Remove the screws from left and right handle on the system.
移除服务器上左右把手的螺钉。
- 2 Direction of the arrow out of the .
依箭头方向拉出服务器。
- 3 Press members and remove the inner rail in the direction of the arrow.
按下部件并依箭头方向取出服务器。

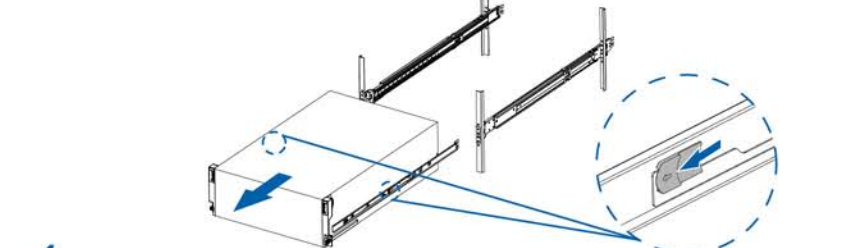
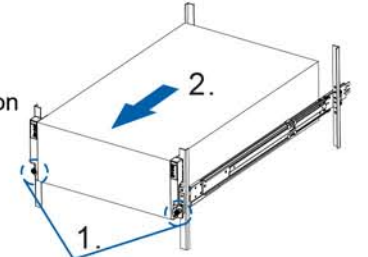

- 4 Off shrapnel taken out of the rail in the direction of the arrow.
拉开弹片依箭头方向取出内轨。

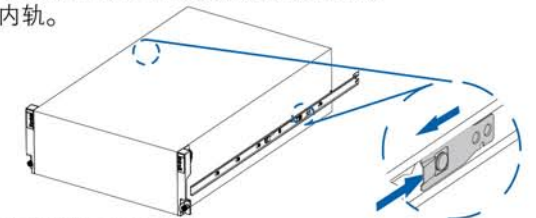

- 5 Remove the rails by a step and the step b.
a. This member by pressing the arrow direction 1-2 Removing the front bracket.
b. This member by pressing the arrow direction 1-2 Removing the rear bracket.
请依a步骤和b步骤取下导轨。
a. 按压部件依箭头1-2方向卸下前支架。
b. 按压部件依箭头1-2方向卸下后支架。

